

EXCAVATOR ZE700Esp



ZOOMLION

Zoomlion Heavy Industry Science & Technology Co.,Ltd.

Add:Zoomlion Overseas Building, No.613, 3rd Section, Furong Middle Road, Yuhua District, Changsha, Hunan, P.R.China 410205

Copyright © 2015 Zoomlion. All rights reserved. Reproduction and copying of any part of the Contents is not allowed for any purposes without Zoomlion's written approval.
Note: No product coating appearance shall be subject to sample.



Printed in China.VN: EN-EM-2016-01

ZOOMLION

Features

The power system of ZE700E series excavator is equipped with Cummins engine featuring large power, high quality, low fuel consumption and less noise. As a precise mechanic-electronic-hydraulic integrated control system, the Kawasaki hydraulic system can realize large flow and high power control. Working together with a large-capacity bucket, it makes operations more efficient, stable and reliable. The user-friendly design of machine makes operations more comfortable. The rationalized maintenance layout makes maintenance more convenient. Bluedon management system is used to monitor machine performance and make management more convenient. The dashboard display is provided with standard configuration of interface with six languages, such as Chinese, English, French, Russian, Spanish, Portuguese, etc, to meet demands of different countries and regions. The machine boasts powerful digging force and fast operating speed. Equipped with large-capacity bucket, it can realize excellent production efficiency. This series of large-scale hydraulic excavator is mainly used in the large-scale engineering projects of mining, huge infrastructure construction, marine reclamation land and harbour channel dredging.

ZE700Esp excavator is equipped with enlarged rock bucket, shorter boom, shorter arm, as well as advanced electrical system and hydraulic system. The machine boasts stable performance, powerful digging force and fast operating speed. This excavator is widely used in the large-scale engineering projects of mining, huge infrastructure construction, marine reclamation land and harbour channel dredging.

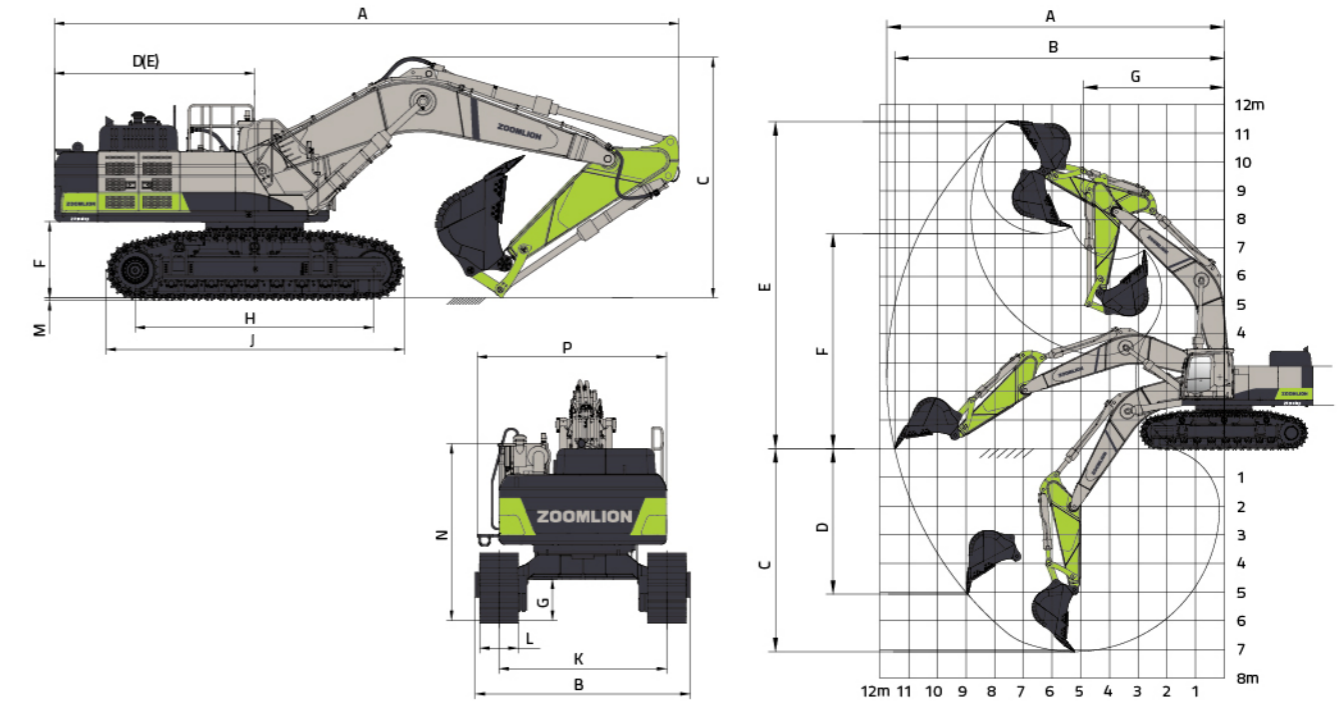

Technical Parameters

	Item	ZE700E	ZE700Esp
Key technical parameters	Working mass (kg)	71000	70000
	Rated power(kw /rpm)	354/1800	354/1800
	Standard bucket capacity(SAE) (m³)	3.2	4.1
	System flow (Max. pressure/ Max. flow)	31.4 /34.3 Mpa 1036 L/min	31.4 /34.3 Mpa 1036 L/min
	Engine model	Cummins QSX15(475hp)	Cummins QSX15(475hp)
	Max. torque(N.m/rpm)	2203/1400	2203/1400
	Traveling speed (low/high)(km/h)	3.05/4.24	3.05/4.24
	Slewing speed (rpm)	6.8	6.8
	Gradeability°	35°	35°
	Max. drawbar pull(kN)	489	489
	Digging force of bucket (ISO)(kN)	388	385
	Digging force of stick (ISO)(kN)	252	312

Dimension And Operation Range

	Item	ZE700E	ZE700Esp	
Basic parameters	A	Length(mm)	13110	12340
	B	Width (mm)	4050	4154
	C	Height (mm)	4760	4675
	D	Slewing radius of tail (mm)	3940	3940
	E	Tail length(mm)	3940	3940
	G	Counterweight ground clearance(mm)	1502	1502
	H	Min. ground clearance(mm)	820	820
	I	Ground contact length(mm)	4690	4690
	J	Track length(mm)	5870	5870
	K	Track gauge(mm)	3300	3300
	M	Track shoe width(mm)	750	750
	P	Height (UP to the top of the cab) (mm)	3545	3545
	Operating range	Q	Slewing table width(mm)	3940
A		Max. excavating radius(mm)	3940	3940
B		Max. excavating distance(mm)	1502	1502
C		Max. excavating height(mm)	820	820
D		Max. discharging height(mm)	4690	4690
E		Max. excavating depth(mm)	5870	5870
F		Max. vertical excavating depth(mm)	3300	3300
G	Min. slewing radius of front(mm)	4050	4050	